

# Model SP-22HA & SP-22HI

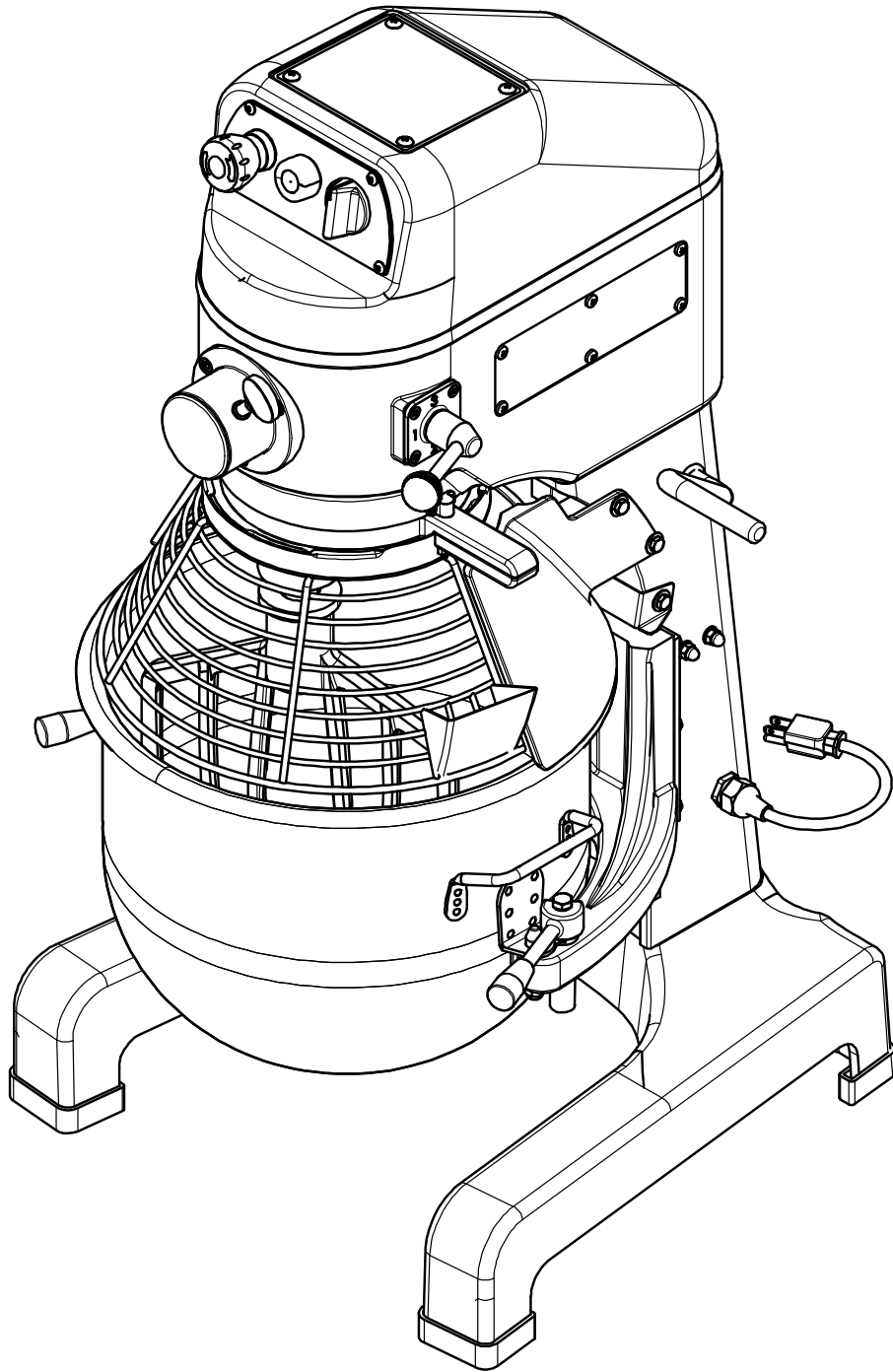

2016 Version

# SP-22HA & SP-22HI TOP COVER UNIT

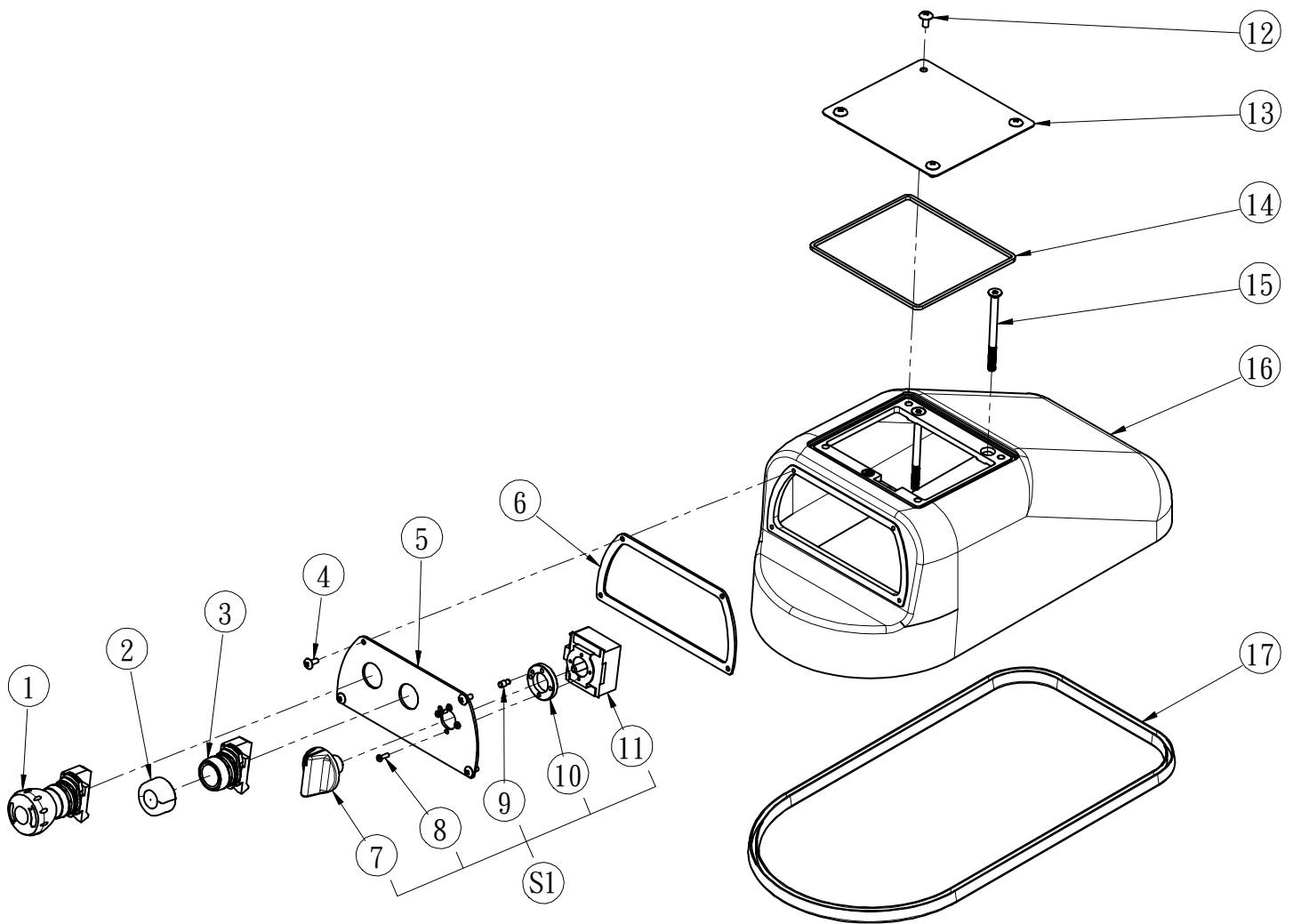

ITEM	PART NO.	Q'ty	REMARK
1	J101-001	1	
2	200517	1	
3	J202-001	1	
4	A106-A0805-D	4	
5	22005	1	
6	22005-A	1	
S1	22008	1	ASSEMBLY PART
7	22008-2	1	
8	A104-A0605-A2/G1	4	
9	22008-3	1	
10	22008-1	1	
11	J301-001	1	
12	A105-A1005-A1	4	
13	22002	1	
14	22003	1	
15	A108-A1120-C4	2	
16	22004	1	
17	22004-2	1	LENGTH IS DIFFERENT SUBJECT TO MODEL. PLEASE SPECIFY MODEL WHEN ORDERING.

# SP-22HA & SP-22HI HEAD UNIT

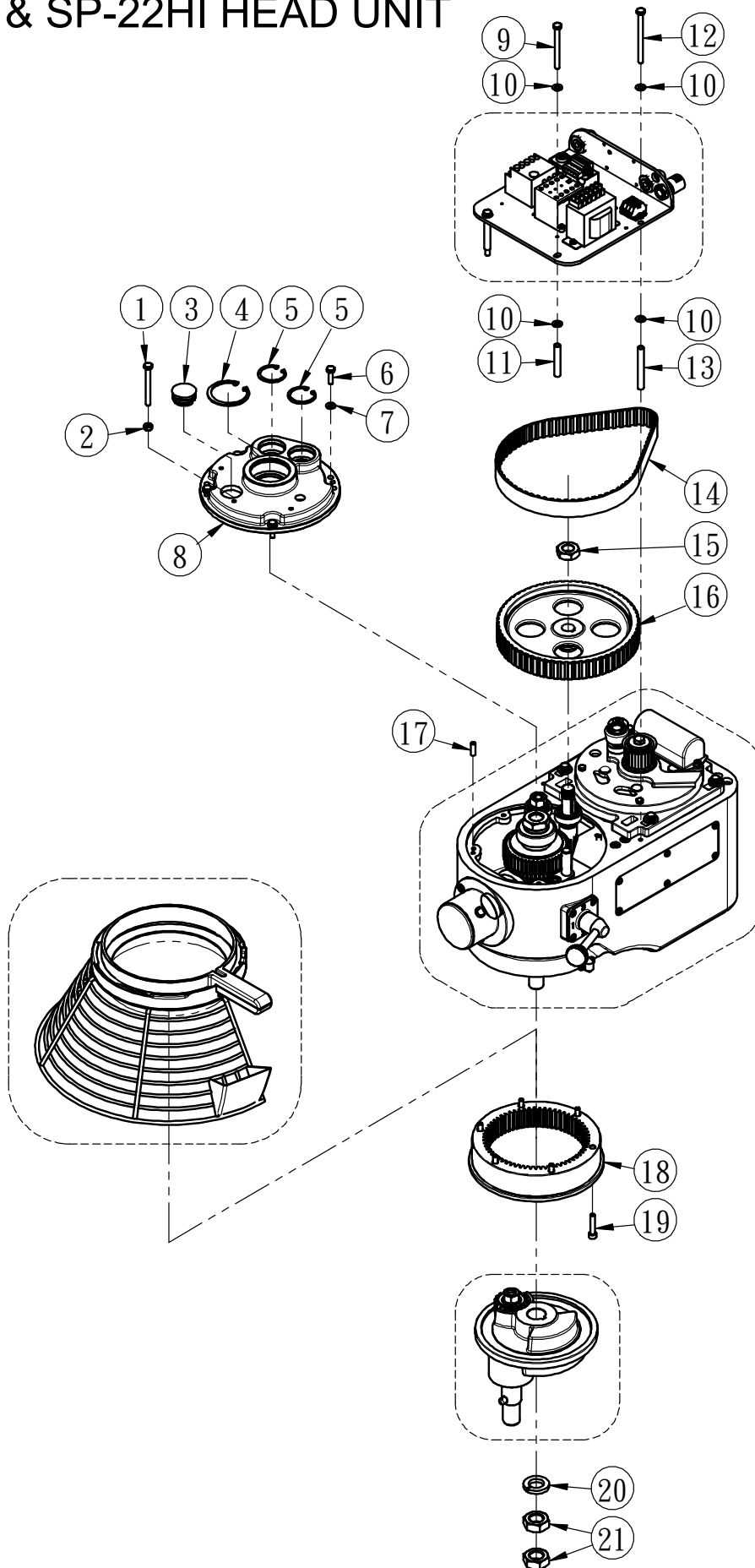

# SP-22HA & SP-22HI HEAD UNIT- PARTS TABLE

ITEM	PART NO.	Q'ty	REMARK
1	A101-A1117-A1	1	WITH ATTACHMENT HUB USE ONLY
	A101-A1120-A1	1	NO ATTACHMENT HUB USE ONLY
2	A201-A11-A1	1	WITH ATTACHMENT HUB USE ONLY
3	T901-001	1	
4	RTW-52	1	
5	RTW-35	2	
6	A101-A1109-A1	4	
7	A302-A11-B4	4	
8	22072	1	
9	A101-A1118-A1	2	
10	A301-A11-13-1-A1	8	
11	22013	2	
12	A101-A1120-A1	2	
13	22080	2	
14	22067	1	
15	A201-D08T080-A1	1	
16	22075	1	
17	200074-1	2	
18	22088	1	
19	A102-A1111-C4	6	
20	A302-C09-A1	1	
21	A201-D09T100-A1	2	

# SP-22HA & SP-22HI HEAD ASSEMBLY EXPLODED VIEW

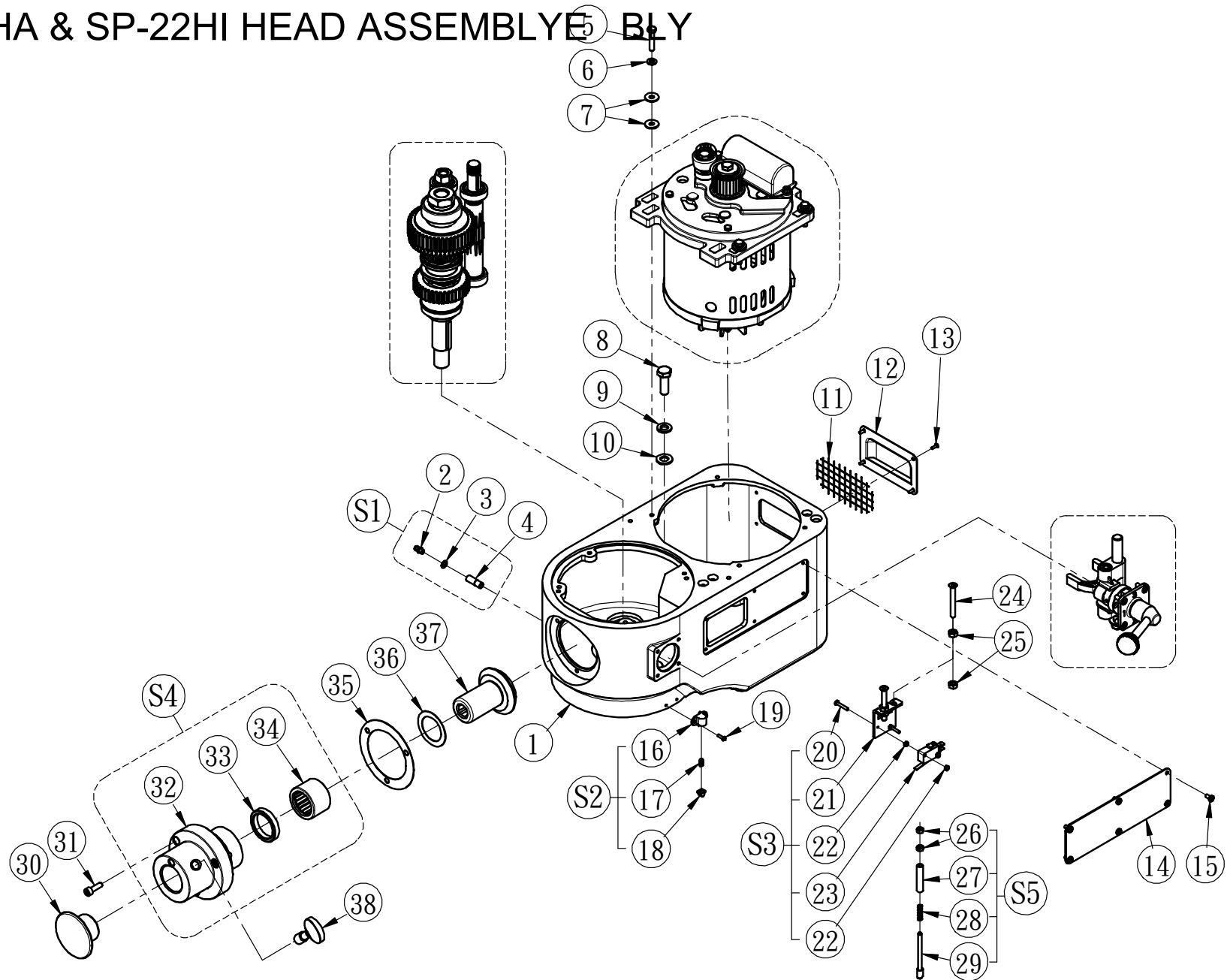

# SP-22HA & SP-22HI HEAD ASSEMBLY- PARTS TABLEBLY

ITEM	PART NO.	Q'ty	REMARK
1	22082-2	1	SP-22HA USE WITH ATTACHMENT HUB
	22082-3	1	SP-22A USE WITHOUT ATTACHMENT HUB
	22082	1	SP-22HI USE WITH ATTACHMENT HUB
	22082-1	1	SP-22I USE WITHOUT ATTACHMENT HUB
S1	200142S	1	ASSEMBLY PART
2	200142	1	
3	200141	1	
4	200140	1	
5	A101-A1111-A1	4	
6	A302-A11-A1	4	
7	A301-A11-19-1-A1	8	
8	A101-A1511-A1	4	
9	A302-A15-B4	4	
10	A301-A15-20-1-A1	4	
11	SN-30-001	1	
12	22071	1	
13	A701-32089	4	
14	22061	1	
15	A105-A0804-D	6	
S2	200075	1	ASSEMBLY PART
16	200075-A	1	
17	200075-1	1	
18	200075-B	1	
19	A106-A0604-D	2	
S3	200058S	1	ASSEMBLY PART
20	A105-A0609-A1	2	
21	200058	1	
22	A201-A06-A1	4	
23	J404-001	1	
24	A107-A1115-A1	2	
25	A201-A11-A1	4	
S5	200043S	1	METAL ONE; ASSEMBLY PART
	200043-1S	1	PLASTIC ONE; ASSEMBLY PART
26	A201-A10-A1	2	
27	22091	1	
28	200044	1	
29	200043	1	METAL ONE
	200043-1	1	PLASTIC ONE
30	22017	1	
31	A102-A1110-C4	3	
S4	22018S	1	ASSEMBLY PART
32	22018	1	
33	TC-354508	1	
34	A503-TA3530	1	
35	22018-A	1	
36	200006-1	1	
37	200003	1	
38	200005	1	

# SP-22HA & SP-22HI GEAR BOX ASSEMBLY BLY

## Master Shaft Assembly

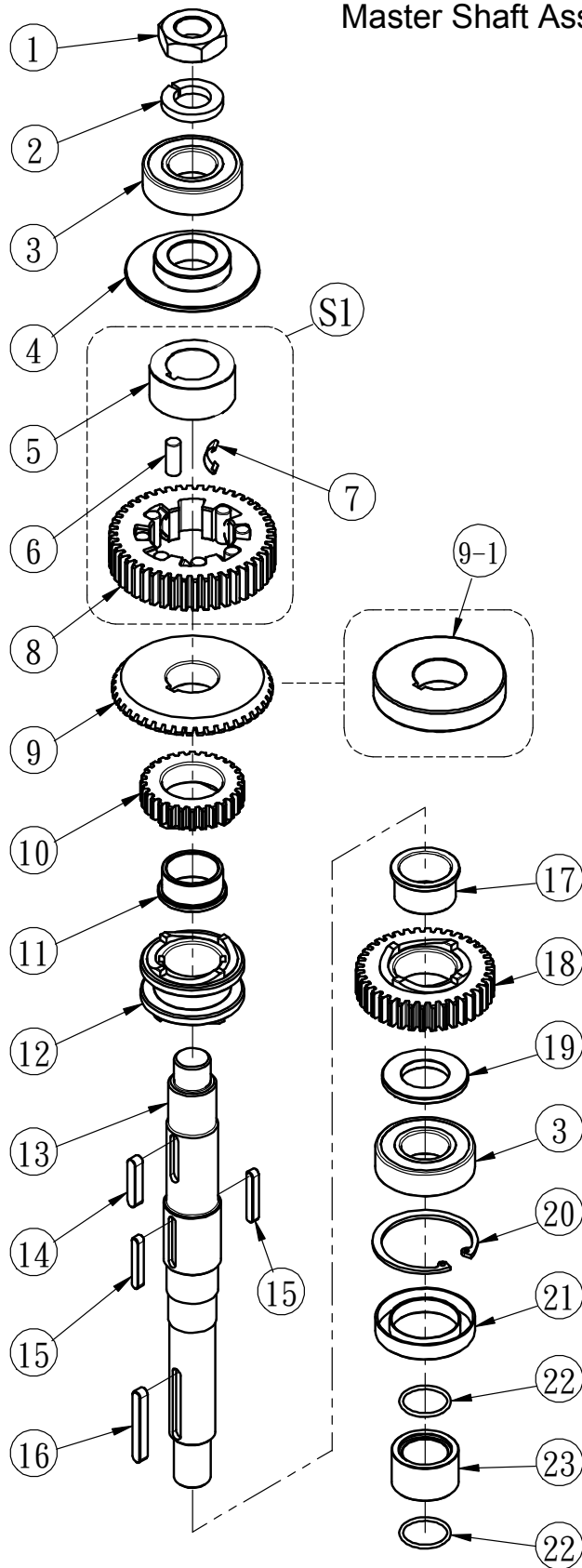

SP-22HA & SP-22HI GEAR BOX ASSEMBLY  
PARTS TABLE- Master Shaft AssemblymE BLY

ITEM	PART NO.	Q'ty	REMARK
1	A201-D09T100-A1	1	
2	A302-C09-B4	1	
3	A502-6205LLU	2	
4	22107	1	
S1	22111S	1	ASSEMBLY PART
5	22108	1	
6	22109	8	
7	22110	8	
8	22111	1	
9	200095	1	WITH ATTACHMENT HUB USE ONLY
9-1	200095-1	1	NO ATTACHMENT HUB USE ONLY
10	22113	1	
11	200099	1	
12	200110	1	
13	22124	1	
14	A402-060630	1	
15	A402-050532	2	
16	A402-060645	1	
17	22116	1	
18	22117	1	
19	200101	1	
20	RTW-52	1	
21	TC-355210	1	
22	A601-023-01	2	
23	22121	1	



# SP-22HA & SP-22HI GEAR BOX ASSEMBLY BLY

## Transmission Shaft Assembly

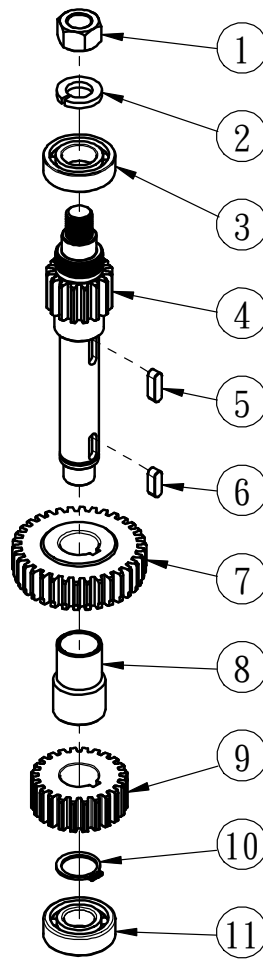

ITEM	PART NO.	Q'ty	REMARK
1	A201-D06-A1	1	
2	A302-C06-B4	1	
3	A502-6003LLU	1	
4	22144	1	
5	A402-050517	1	
6	A402-050515	1	
7	22142	1	
8	200122	1	
9	22137	1	
10	STW-19	1	
11	A502-6202	1	

# SP-22HA & SP-22HI GEAR BOX ASSEMBLY BLY

## Drive Shaft Assembly

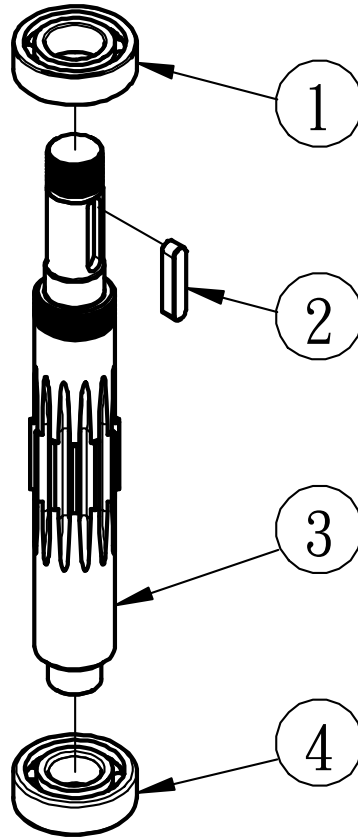

ITEM	PART NO.	Q'ty	REMARK
1	A502-6003LLU	1	
2	A402-050525	1	
3	22139	1	
4	A502-6202	1	

# SP-22HA & SP-22HI SPEED HANDLE & YOKE-SHIFTER ASSEMBLY

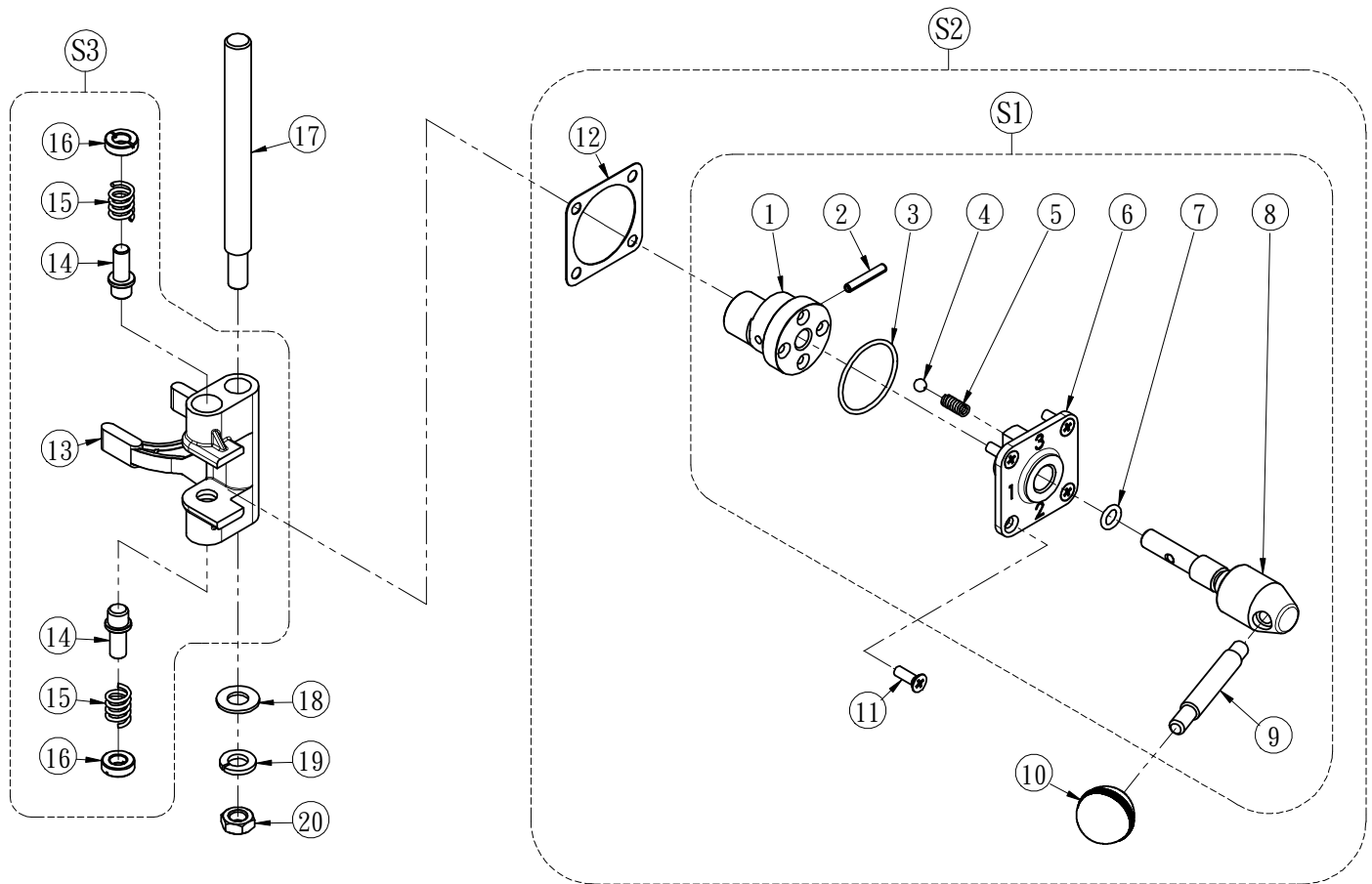

ITEM	PART NO.	Q'ty	REMARK
S1	22053S	1	ASSEMBLY PART WITHOUT #10, #11 & #12
1	-	1	
2	-	1	
3	-	1	
4	-	2	
5	-	2	
6	-	1	
7	-	1	
8	-	1	
9	200045	1	
S2	200047-AS-1	1	ASSEMBLY PART INCLUDE #10, #11 & #12
10	U101-002	1	
11	A107-A1030-A1	4	
12	200047-A	1	
S3	200116S	1	ASSEMBLY PART
13	-	1	
14	-	2	
15	-	2	
16	-	2	
17	22129	1	
18	A301-A15-20-1-A1	1	
19	A302-C04-B4	1	
20	A201-C04-A1	1	

# SP-22HA & SP-22HI MOTOR ASSEMBLY BLY

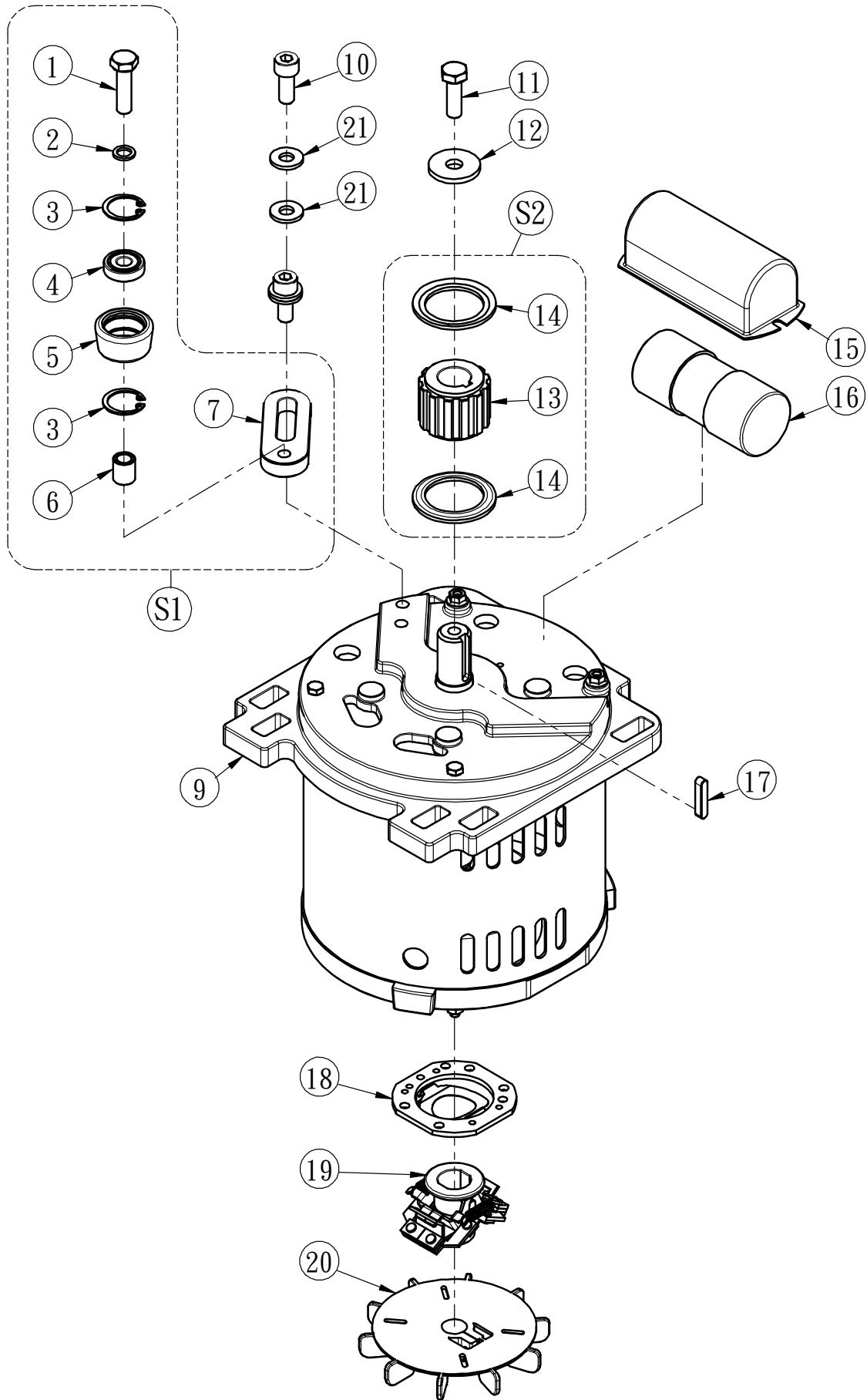

SP-22HA & SP-22HI MOTOR ASSEMBLY  
PARTS TABLEE BLY

ITEM	PART NO.	Q'ty	REMARK
S1	22147-1S	1	ASSEMBLY PART
1	-	1	
2	-	1	
3	-	2	
4	-	1	
5	-	1	
6	-	1	
7	-	1	
8	-	-	
9	22063	1	PLEASE SPECIFY VOLTAGE WHEN ORDERING
10	A102-A1309-C4	2	
11	A101-A1310-A1	1	
12	A301-A13-25-2-A1	1	
S2	22066S	1	15T; 50HZ USE; ASSEMBLY PART INCLUDE #13 & #14
	22066-1S	1	13T; 60HZ USE; ASSEMBLY PART INCLUDE #13 & #14
13	-	1	
	-	1	
14	-	2	
	-	2	
15	SN-22-001	1	
16	K201-300/250	1	SINGLE PHASE VOLTAGE USE ONLY
17	A402-050525	1	
18	J701-001	1	SINGLE PHASE VOLTAGE USE ONLY
19	J802-14-50	1	50HZ; SINGLE PHASE VOLTAGE USE ONLY
	J802-14-60	1	60HZ; SINGLE PHASE VOLTAGE USE ONLY
20	T801-14-128-10	1	
21	A301-A13-18-1-A1	4	

# SP-22HA & SP-22HI PLANETARY UNIT

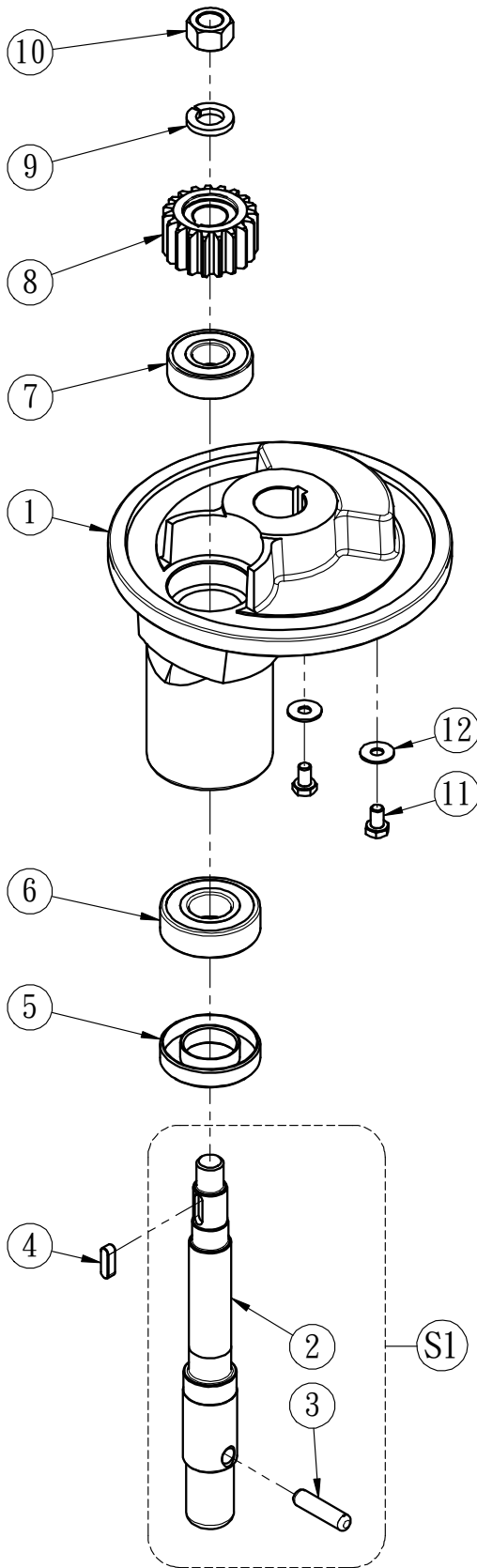

ITEM	PART NO.	Q'ty	REMARK
1	200011	1	
S1	200015S	1	ASSEMBLY PART
2	200015	1	
3	22028	1	
4	A402-050517	1	
5	TC-254710	1	
6	A502-6204ZZ	1	
7	A502-6203ZZ	1	
8	200009	1	
9	A302-C06-B4	1	
10	A201-D06-A1	1	
11	A101-A1105-A1	2	
12	A301-A11-16-1-A1	2	

# SP-22HA REMOVABLE SAFETY GUARD UNIT

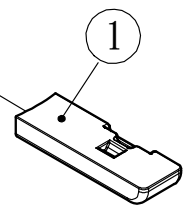
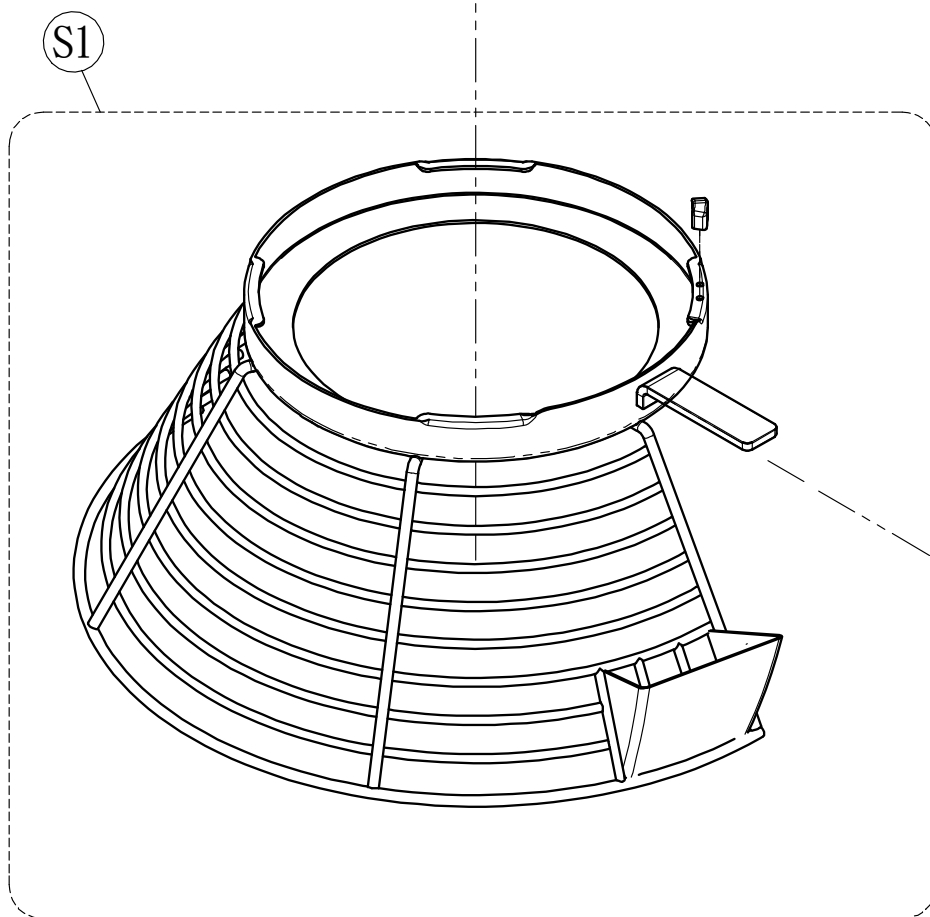
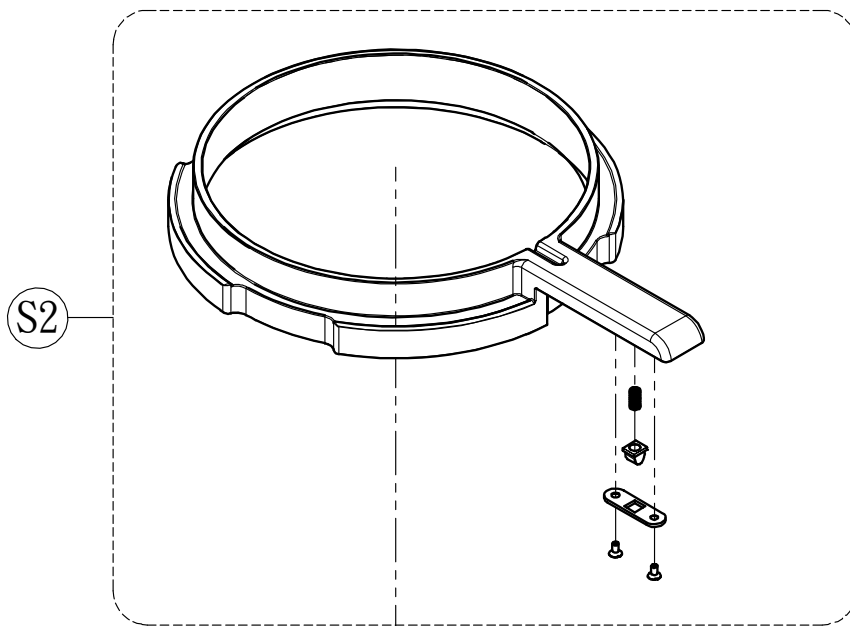

ITEM	PART NO.	DESCRIPTION	Q'ty	REMARK
S1	22508S	SAFETY GUARD- REMOVABLE TYPE	1	ASSEMBLY PART
1	200504	PLASTIC HANDLE	1	
S2	200076-2S	PLASTIC SLIDE SHEATH- REMOVABLE TYEP	1	ACCEMBLY PART

# SP-22HI SAFETY GUARD UNIT- FIXED TYPE

Metal Slide Sheath

Plastic Slide Sheath

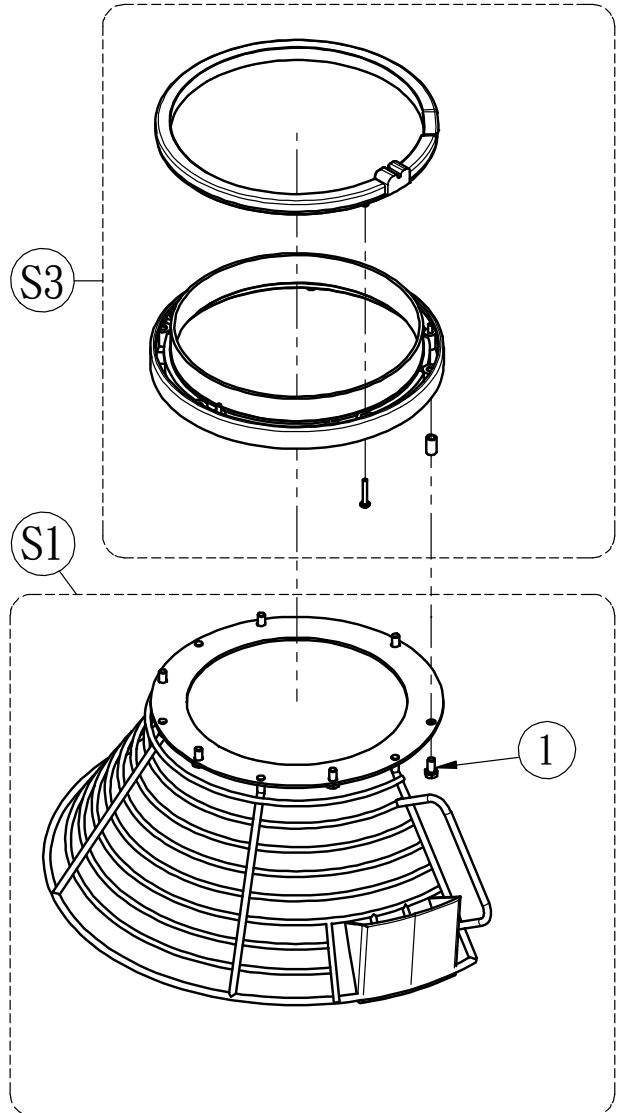
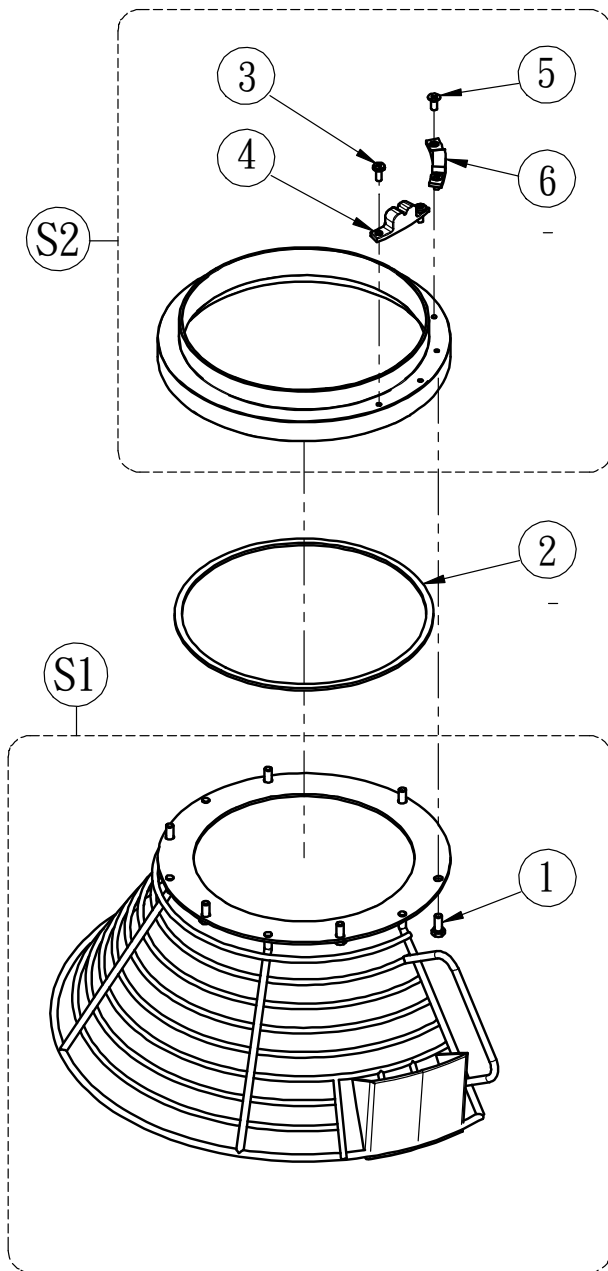

ITEM	PART NO.	Q'ty	REMARK
S1	22090S	1	ASSEMBLY PART; SP-200 USE ONLY
1	A101-A1005-DB/G1	6	
2	200077	1	MUST USE WITH 22090S
S2	200076-1S	1	METAL ONE; ASSEMBLY PART
3	A105-A0805-D	2	
4	22156	1	
5	A107-A0805-D	2	
6	200041	1	
S3	200076	1	PLASTIC ONE; ASSEMBLY PART



# SP-22HA & SP-22HI ELECTRONIC PART ASSEMBLY

ETL SPEC.

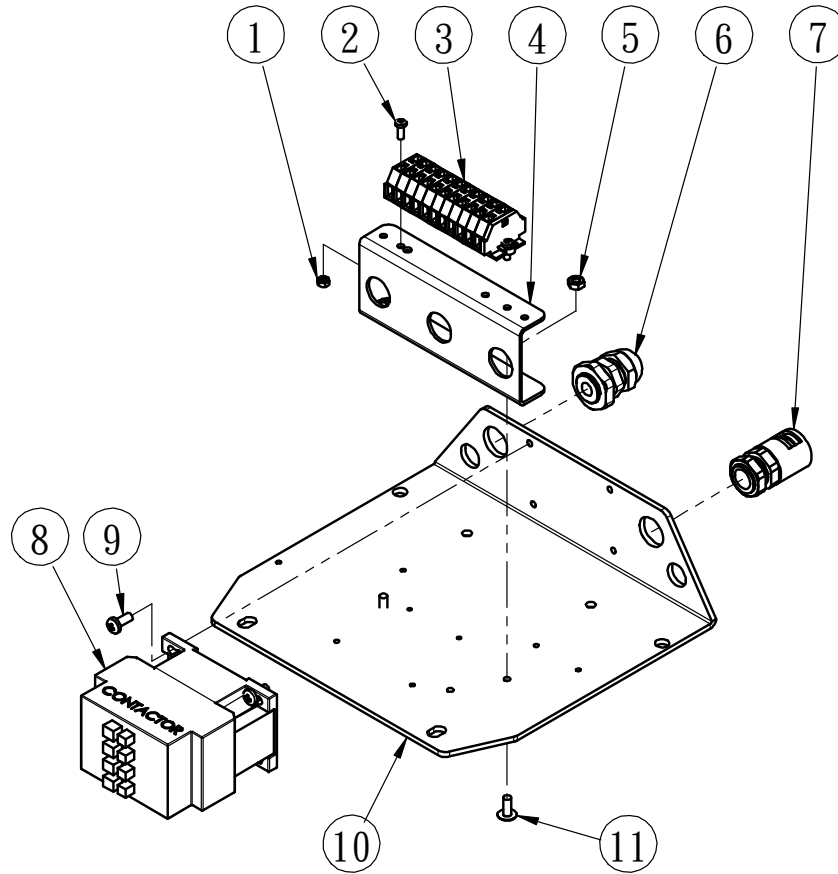

ITEM	PART NO.	Q'ty	REMARK
1	A201-A06-A1	2	
2	A105-A0604-A1	2	
3	22HI/12	1	SPECIFICATION IS DIFFERENT SUBJECT TO ETL AND CE SPEC. PLEASE SPECIFY ETL OR CE SPEC. WHEN ORDERING
4	22014-A	1	
5	A201-A08-A1	2	
6	T102-001	1	
7	T101-001	1	
8	22HI/11	1	SPECIFICATION IS DIFFERENT SUBJECT TO ETL AND CE SPEC. PLEASE SPECIFY VOLTAGE, ETL OR CE SPEC. WHEN ORDERING
9	A105-A0805-A1	2	
10	22014-N	1	
11	A106-A0805-A1	2	

# SP-22HA & SP-22HI ELECTRONIC PART ASSEMBLY

CE SPEC.

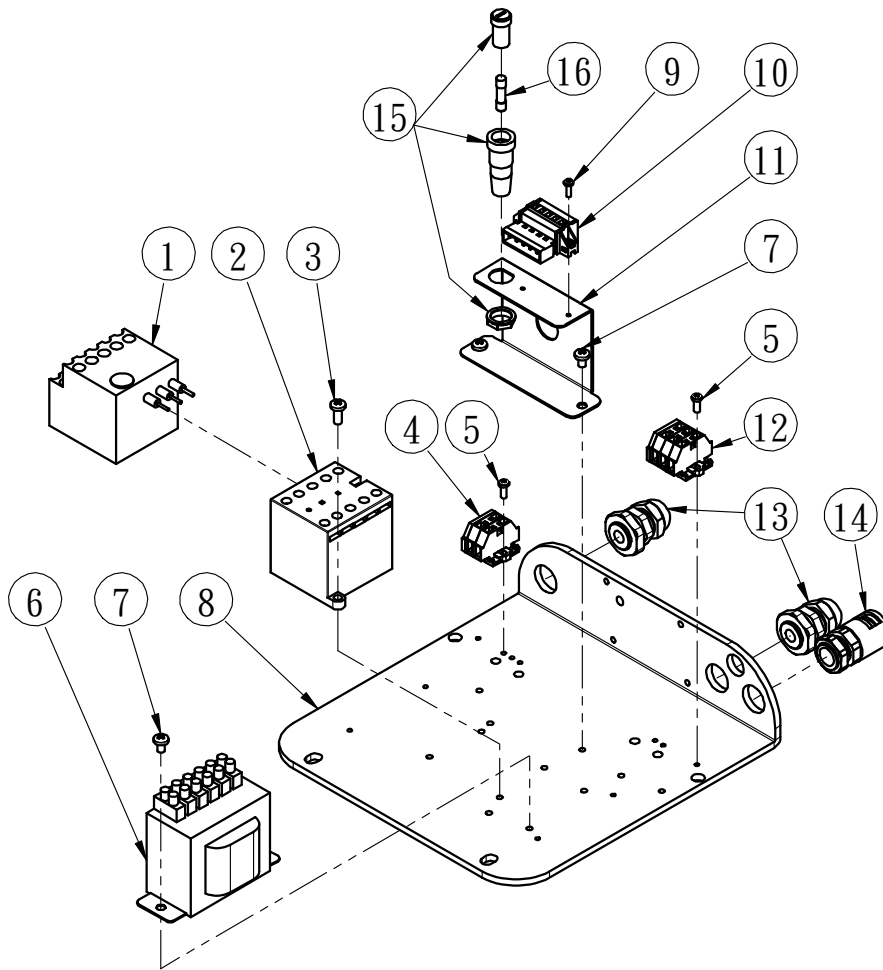

ITEM	PART NO.	Q'ty	REMARK
1	22HI/152	1	SPECIFICATION IS DIFFERENT SUBJECT TO ETL AND CE SPEC. PLEASE SPECIFY VOLTAGE, ETL OR CE SPEC. WHEN ORDERING
2	22HI/11	1	SPECIFICATION IS DIFFERENT SUBJECT TO ETL AND CE SPEC. PLEASE SPECIFY VOLTAGE, ETL OR CE SPEC. WHEN ORDERING
3	A105-A0805-A1	2	
4	22HI/12	1	SPECIFICATION IS DIFFERENT SUBJECT TO ETL AND CE SPEC. PLEASE SPECIFY ETL OR CE SPEC. WHEN ORDERING
5	A105-A0604-A1	4	
6	22HI/151	1	CE SPEC. USE. PLEASE SPECIFY VOLTAGE WHEN ORDERING
7	A105-A0803-A1	4	
8	22014	1	
9	A105-A0504-D	2	
10	L101-605/019	1	
11	22014-1	1	
12	22HI/12	1	SPECIFICATION IS DIFFERENT SUBJECT TO ETL AND CE SPEC. PLEASE SPECIFY ETL OR CE SPEC. WHEN ORDERING
13	T102-001	2	
14	T101-001	1	
15	L302-6.3-250	1	
16	L301-A-1-250	1	

# SP-22HA & SP-22HI BODY AND BASE UNIT

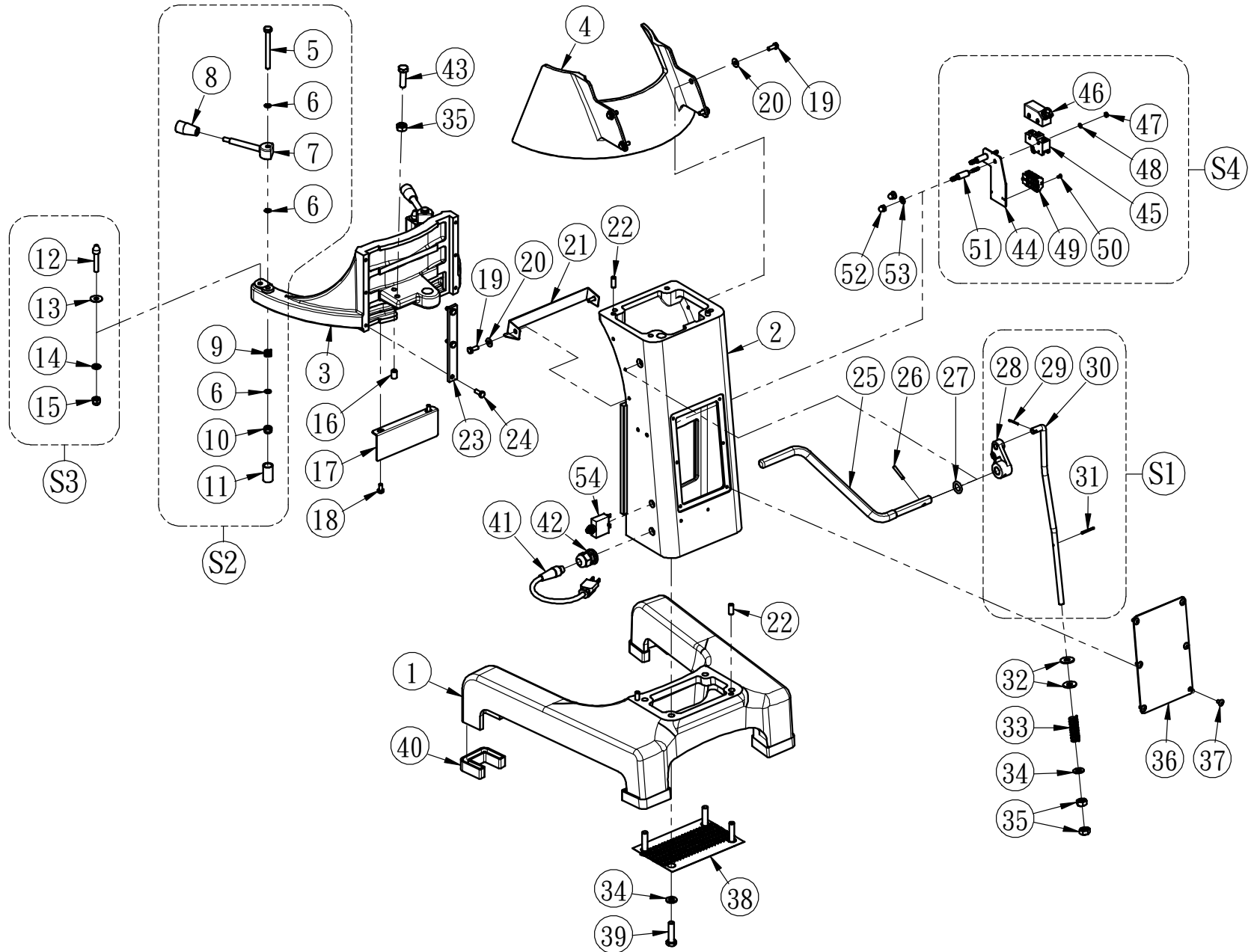

# SP-22HA & SP-22HI BODY AND BASE UNIT PARTS TABLE

ITEM	PART NO.	Q'ty	REMARK
1	22038	1	
2	22044	1	
3	22034	1	
4	22036	1	
S2	RC033S	2	ASSEMBLY PART
5	A101-A1320-A1	2	
6	A301-A13-12-1-A1	6	
7	RC033	2	
8	RC033-1	2	
9	200146	2	
10	A202-A13080-A1	2	
11	200155	2	
S3	22100S	2	ASSEMBLY PART
12	22100	2	
13	A301-A13-22-1-D	2	
14	A302-A13-A1	2	
15	A204-A13-A1	2	
16	A103-A1508-C4	1	
17	22149	1	
18	A202-A13080-A1	2	
19	A101-A1108-D	6	
20	A301-A11-16-1-D	6	
21	22102	1	
22	200035-1	4	
23	200022	2	
24	A101-A1108-A1	6	
25	22049	1	
26	200039	1	
27	A601-015-01	1	
S1	22046S	1	ASSEMBLY PART
28	22048	1	
29	A903-001	1	
30	22046	1	
31	A902-03030	1	

# SP-22HA & SP-22HI BODY AND BASE UNIT PARTS TABLE

ITEM	PART NO.	Q'ty	REMARK
32	A301-A15-25-1-A1	2	
33	100033	1	
34	A301-A15-20-1-A1	5	
35	A201-A15-A1	3	
36	22050	1	
37	A106-A1005-D	6	
38	22037	1	
39	A101-A1513-A1	4	
40	22157	1	FOUR PCS AS ONE SET
41	-	1	PLEASE SPECIFY VOLTAGE
42	T102-002	1	
43	A101-A1512-A1	1	
S4	22047-2S	1	ASSEMBLY PART
44	22047-2	1	
45	J401-001	1	
46	J501-001	1	
47	A201-A08-A1	2	
48	A301-A08-10-1-A1	2	
49	-	1	
50	A105-A0603-A1	2	
51	22047-1	2	
52	A204-A11-D	2	
53	A301-A11-13-1-A1	2	
54	22HI/42	1	ETL SPEC. USE. PLEASE SPECIFY VOLTAGE
	T501-HP15	1	CE SPEC. USE

# SP-22HA & SP-22HI ACCESSORY LIST

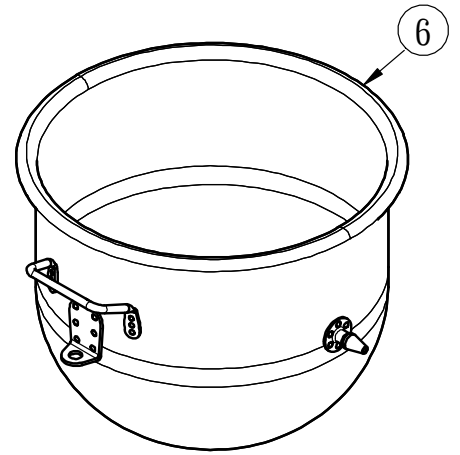
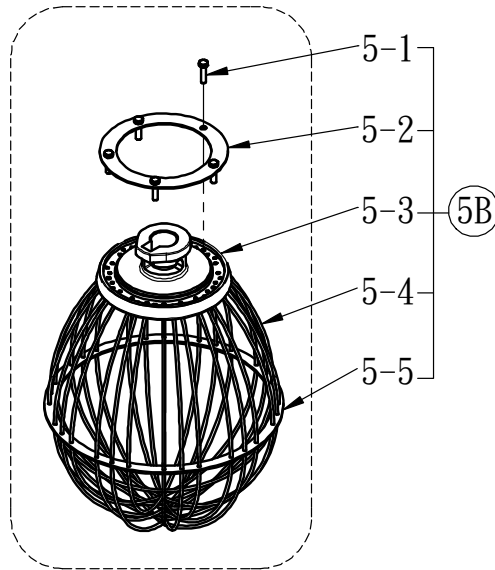
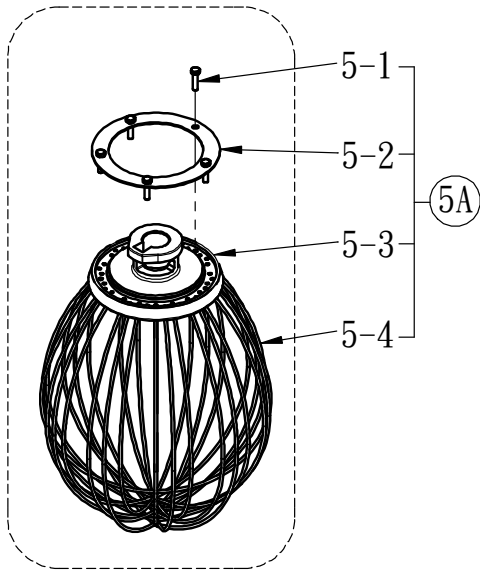
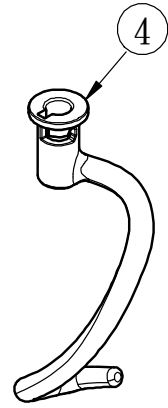
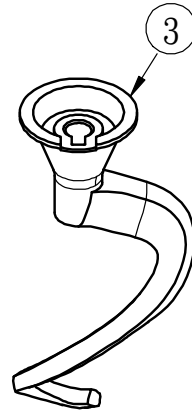
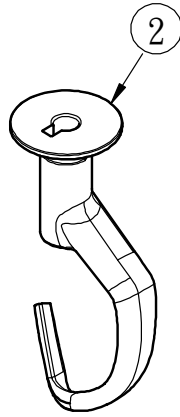
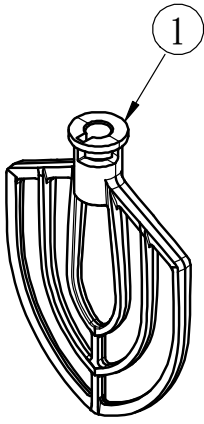

ITEM	PART NO.	DESCRIPTION	Q'ty	REMARK
1	25014	ALUMINUM BEATER	1	STANARD
	22030-1	STAINLESS STEEL BEATER	1	OPTIONAL
2	7M033	J TYPE DOUGH HOOK- ALUMINUM	1	OPTIONAL
3	22029	SPIRAL DOUGH HOOK- ALUMINUM	1	STANDARD
4	22029-1	STAINLESS STEEL SPRIAL DOUGH HOOK	1	OPTIONAL
5A	22031S	WHIP	1	STANDARD
5B	22031-1S	HEAVY DUTY WHIP	1	OPTIONAL
5-1	A101-C0106-D	NUT	5	
5-2	200018-E	RING COVER FOR WHIP	1	
5-3	-		1	
5-4	-		15	
5-5	-		1	
6	22032	BOWL	1	

# SP-22HA & SP-22HA 10QT & 12QT REDUCTION KIT OPTIONAL ACCESSORY

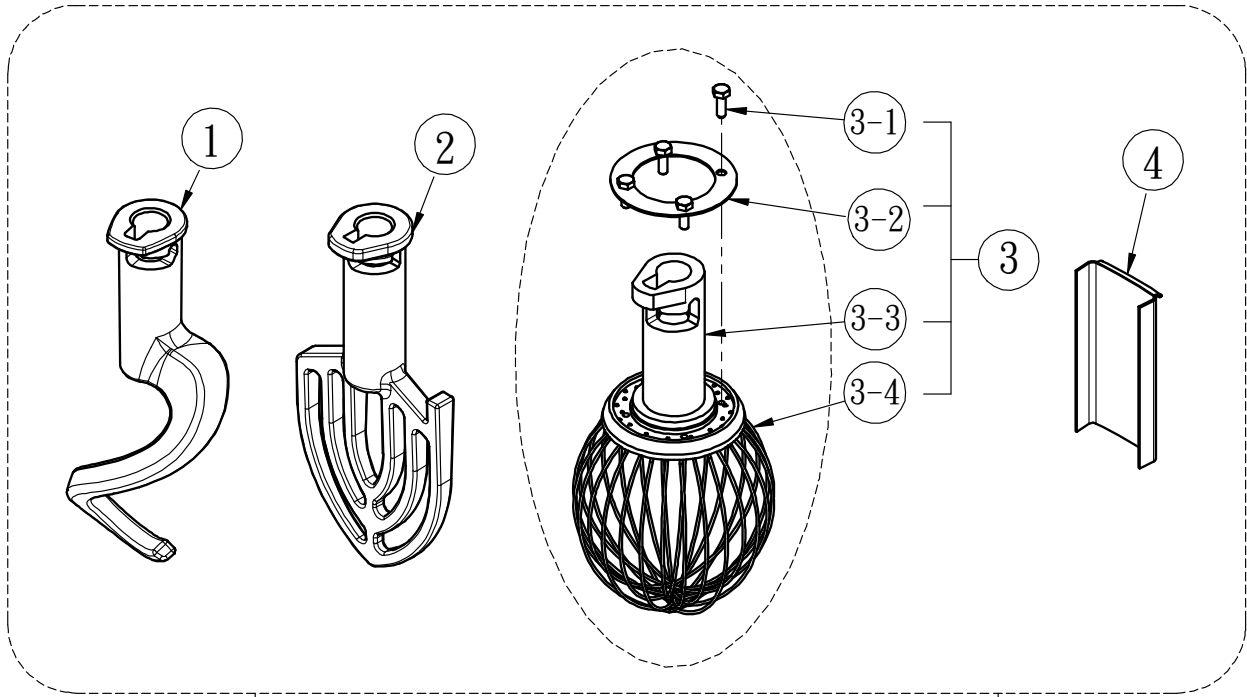

S1

S2

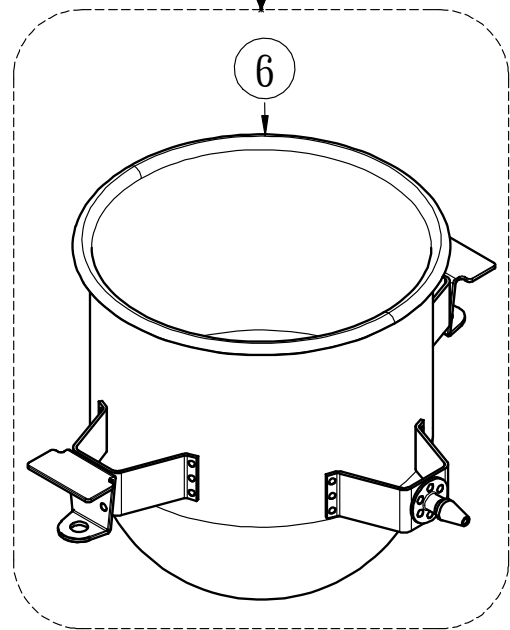
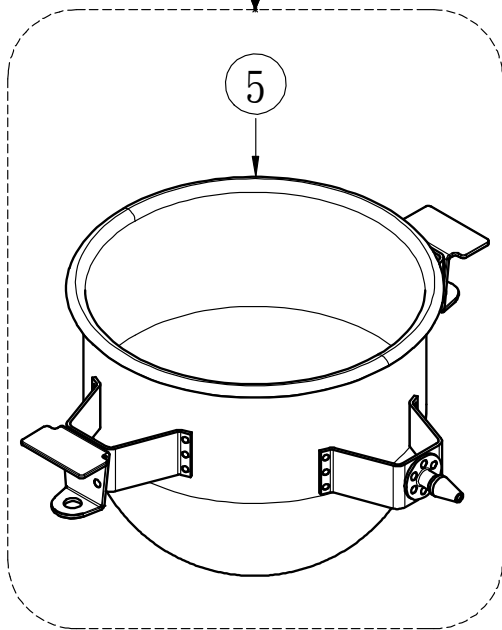

ITEM	PART NO.	DESCRIPTION	Q'ty	REMARK
1	10QT-H-2	REDUCTION 10QT DOUGH HOOK	1	
2	10QT-B	REDUCTION 10QT BEATER	1	
3	10QT-WS	REDUCTION 10QT WHIP	1	
3-1	A101-C0108-D	NUT	4	
3-2	100018-E	RING COVER FOR WHIP	1	
3-3	-		1	
3-4	-		14	
4	22090-2	INGREDIENT CHUTE	1	
5	10QT-22	REDUCTION 10QT BOWL	1	
6	10QT-22L	REDUCTION 12QT BOWL	1	OPTIONAL
S1	10/22ACC	10QT REDUCTION KIT	1	INCLUDE 10QT BOWL, DOUGH HOOK, BEATER AND WHIP
S2	10/22ACC-EX	12QT REDUCTION KIT	1	INCLUDE 12QT BOWL, DOUGH HOOK, BEATER AND WHIP

# SP-22HA & SP-22HA BOWL SCRAPER OPTIONAL ACCESSORY

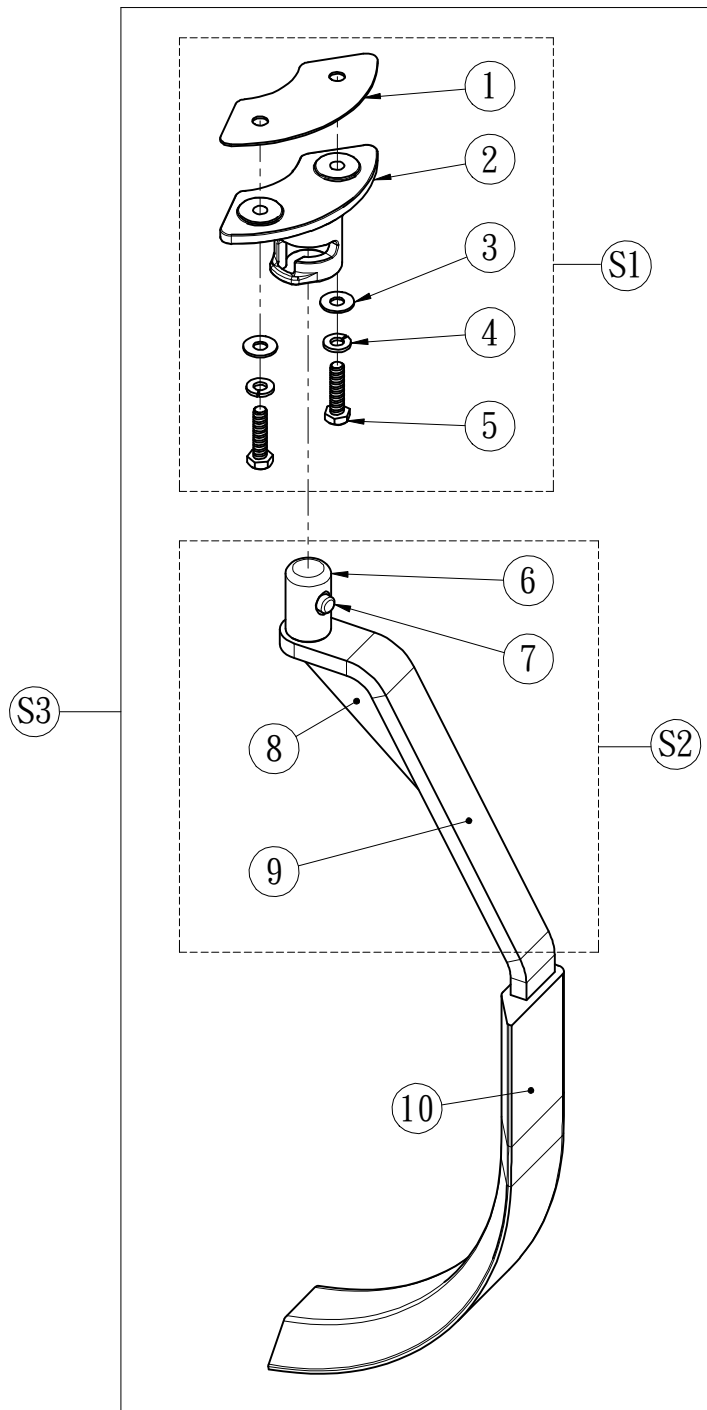

ITEM	PART NO.	Q'ty	REMARK
S3	22/SCRP	1	COMPLETE BOWL SCRAPER SET. INCLUDE S1 &S2
S1	200520S	1	ASSEMBLY PART
1	200519	1	
2	200520	1	
3	A301-A11-19-2-D	2	
4	A302-A11-D	2	
5	A101-A1110-D	2	
S2	22504S	1	ASSEMBLY PART WITHOUT #5
6	200521	1	
7	200522	1	
8	22505	1	
9	22504	1	
10	200525	1	WHITE RUBBER PART